

JARRETT

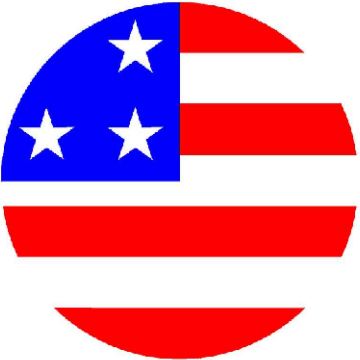

CONCRETE

Jarrett Concrete Products 615-792-9332
2012 Hwy 12 South, Ashland City, TN 37015

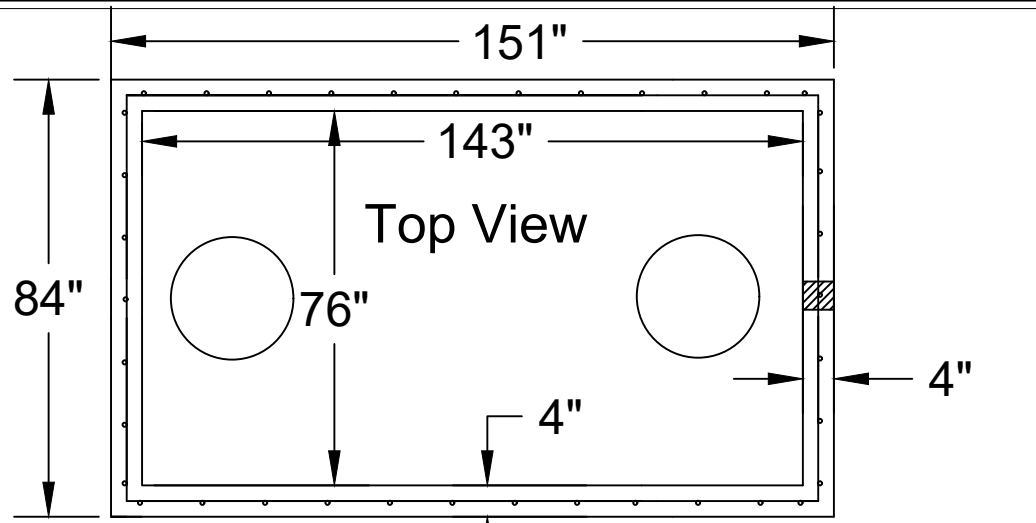

28 Day, 5,000 PSI Concrete
#4 Rebar @12"o.c./e.w. Grade 60
W/ 6" Boots the Inverts Drops 1"
Meets ATSM C-1227, 990, 923
Monolithic Tank Design
"Top Tight" Patent Pending
H-20 Traffic Rated
Print Not To Scale

Cast in place 24"
Orenco riser adapter
on 18" raw hole

Cast in place 24"
Orenco riser adapter
on 20" raw hole

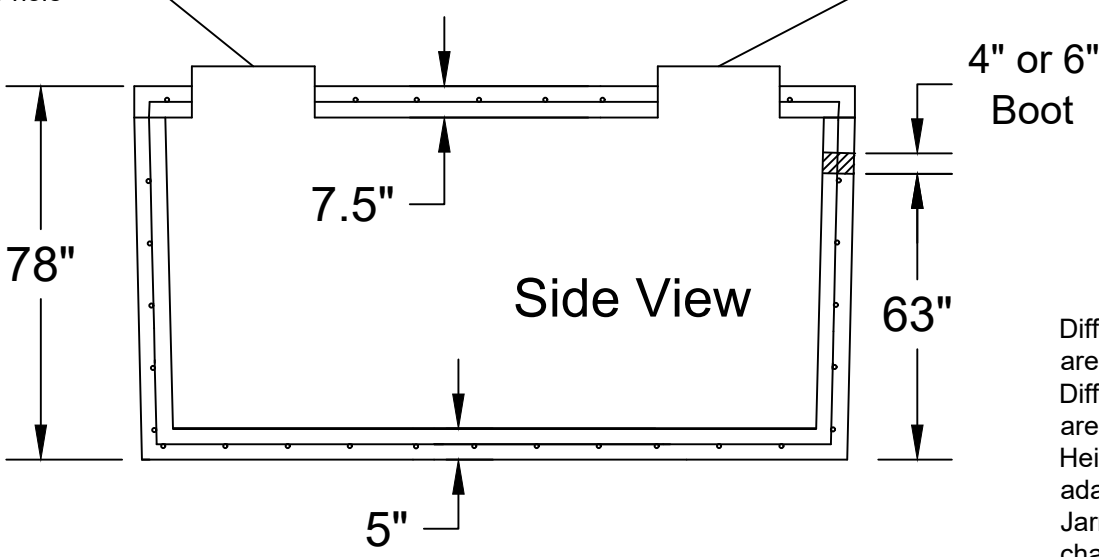

ALL TANKS SOLD BY JCP NEEDS TO BE
WATER TESTED WITHIN FIVE BUSINESS
DAYS FROM THE TIME WE SET THE TANKS.
IF THE TANKS IS NOT TESTED WITHIN FIVE
BUSNISS DAYS, IT IS ASSUMED YOU HAVE
OPTED FOR A VACUUM TEST AT YOUR
EXPENSE. IT IS THE CUSTOMER'S
RESPONSIBILITY TO CORDINATE AND
SCHEDULE THE WATER TEST WITH THE
LOCAL INSPECTOR.

Different inlet size inlet openings and locations
are available by special order.
Different access openings and adaptors rings
are available by special orders.
Height and lengths of tanks can be altered to
adapt to conditions by special order.
Jarrett Concrete reserves the right to make
changes without notice.



S.T.E.P. Septic Tank 2500 Gallon			
Date: 8-20-2019	Drawn By: L.Owen	Weight: 23,139 lbs	