

JARRETT

Jarrett Concrete Products 615-792-9332
2012 Hwy 12 South, Ashland City, TN 37015

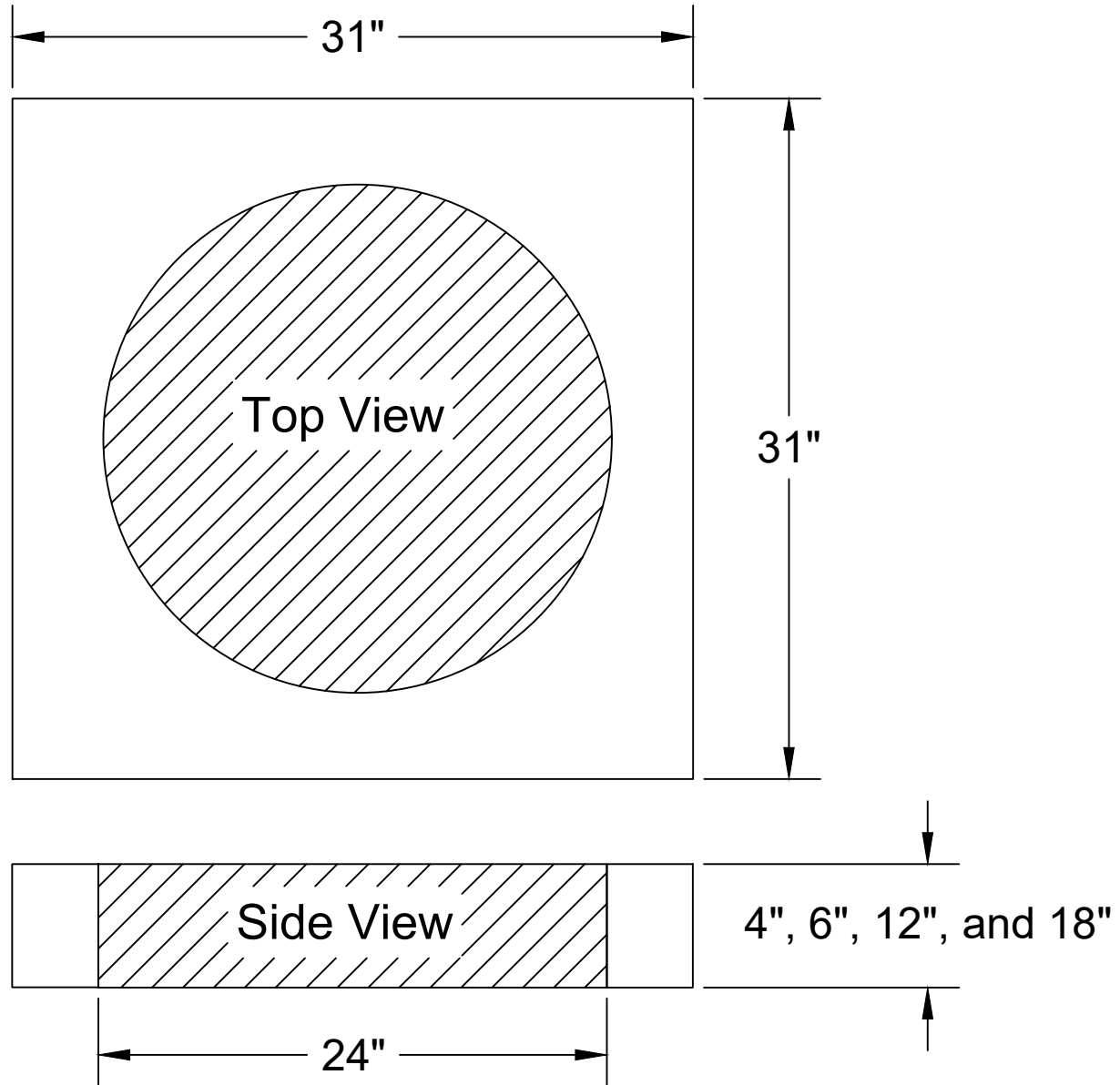
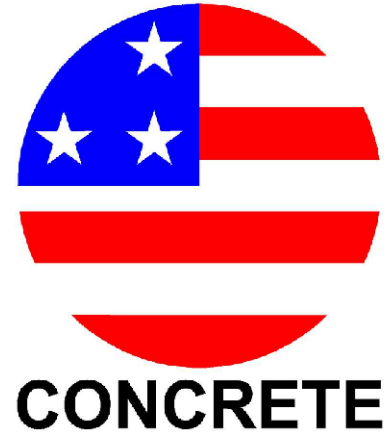

28 Day, 5,000 PSI Concrete
#4 Rebar Grade 60
Meets ATSM C-1227, 990, 923
H-20 Traffic Rated
Print Not To Scale

Grease Trap Riser

Date: 8-10-2021

Drawn By: L.Owen

Weight: 200-800 lbs.

