

# JARRETT

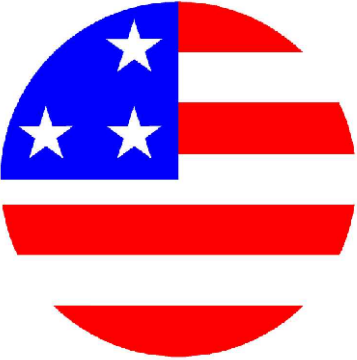

# CONCRETE

28 Day, 5,000 PSI Concrete  
#4 Rebar @12"o.c./e.w. Grade 60  
W/ 6" Boots the Inverts Drops 1"  
Meets ATSM C-1227, 990, 923  
Monolithic Tank Design  
"Top Tight" Patented  
H-20 Traffic Rated

**Jarrett Concrete Products** 615-792-9332  
2012 Hwy 12 South, Ashland City, TN 37015

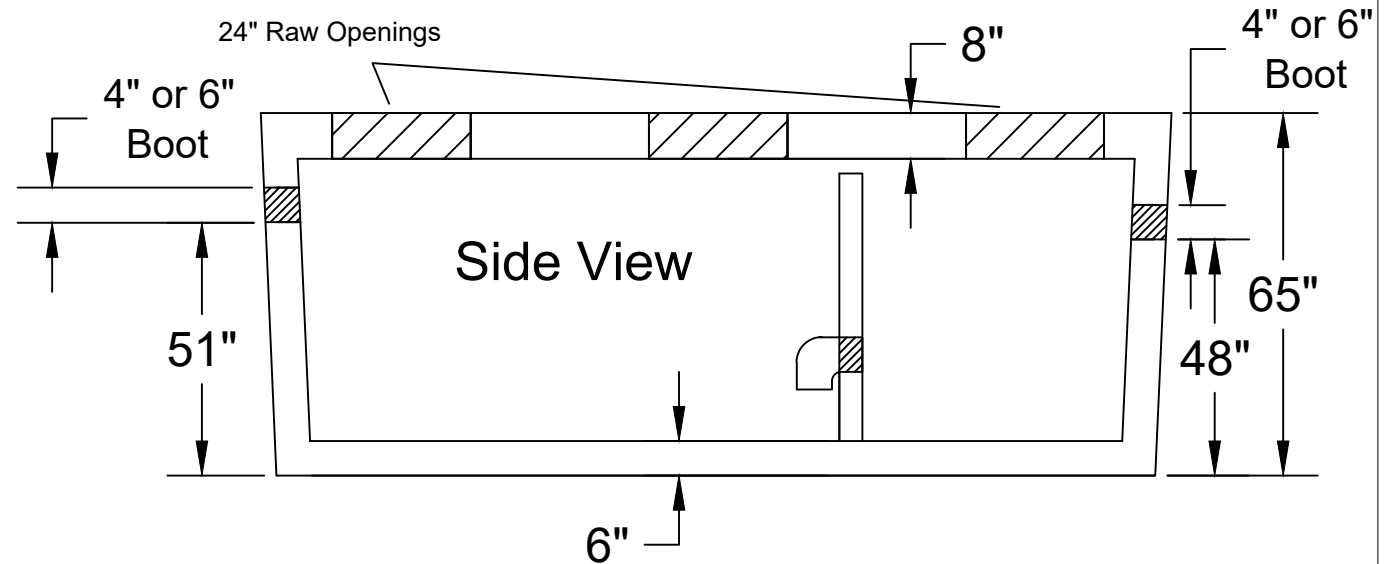
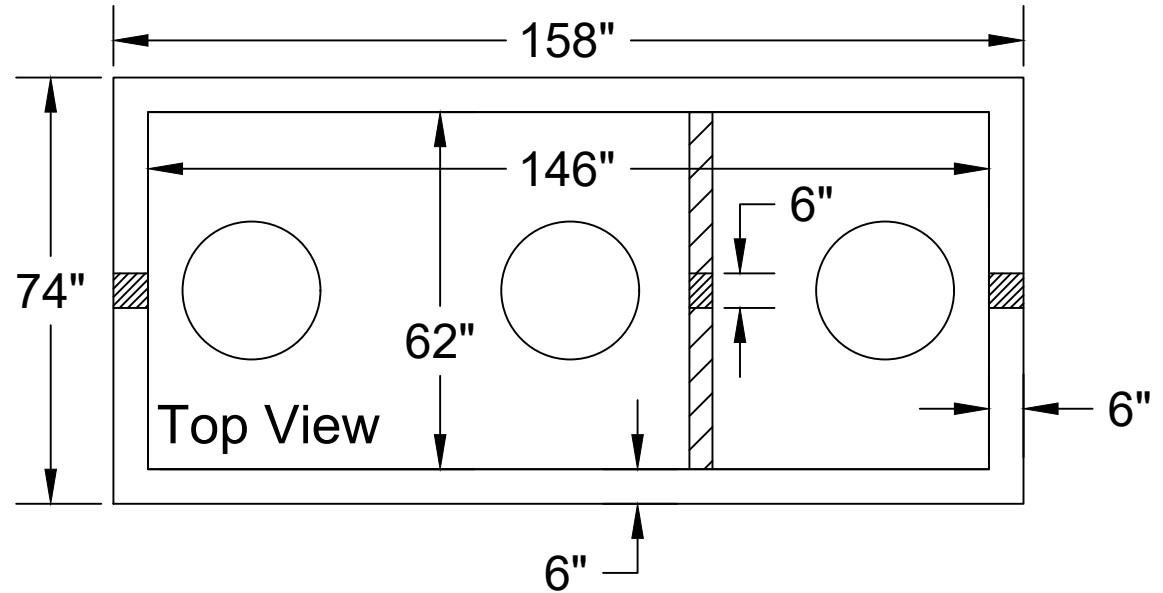

ALL TANKS SOLD BY JCP MUST BE WATER TESTED WITHIN FIVE BUSINESS DAYS FROM THE TIME WE SET THE TANKS. IF THE TANKS IS NOT TESTED WITHIN FIVE BUSINESS DAYS, IT IS ASSUMED YOU HAVE OPTED FOR A VACUUM TEST AT YOUR EXPENSE. IT IS THE CUSTOMER'S RESPONSIBILITY TO COORDINATE AND SCHEDULE THE WATER TEST WITH THE LOCAL INSPECTOR.

**Grease Trap 1500 Gallon**

**Metro-Nashville**

Date: 11-9-2021

Drawn By: L.Owen

Weight: 23,106 lbs

