

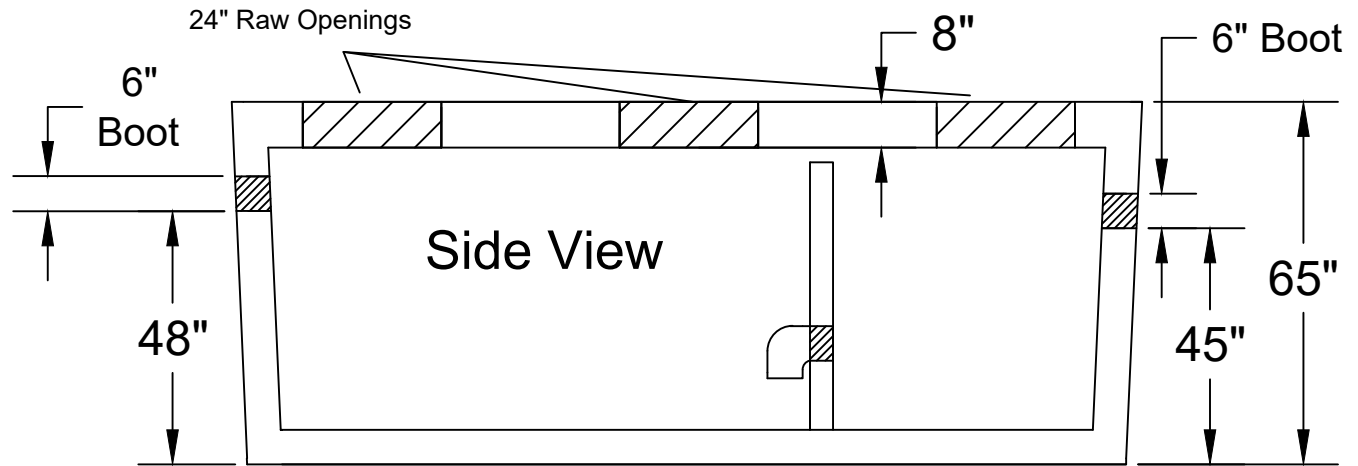

Jarrett Concrete Products 615-792-9332
 2012 Hwy 12 South, Ashland City, TN 37015

28 Day, 5,000 PSI Concrete
 Meets ATSM C-1227, 990, 923
 Monolithic Tank Design
 "Top Tight" Patented
 H-20 Traffic Rated

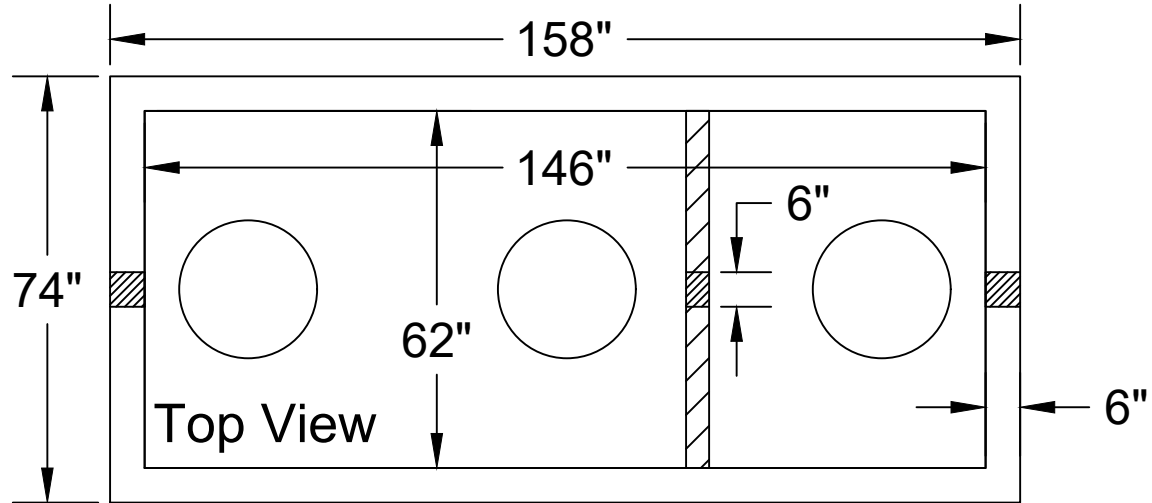

ALL TANKS SOLD BY JCP MUST BE WATER TESTED WITHIN FIVE BUSINESS DAYS FROM THE TIME WE SET THE TANKS. IF THE TANKS IS NOT TESTED WITHIN FIVE BUSINESS DAYS, IT IS ASSUMED YOU HAVE OPTED FOR A VACUUM TEST AT YOUR EXPENSE. IT IS THE CUSTOMER'S RESPONSIBILITY TO COORDINATE AND SCHEDULE THE WATER TEST WITH THE LOCAL INSPECTOR.

Grease Trap 1500 Gallon 6" Boots Davidson-Mt.Juliet

Date: 5-10-2023

Drawn By: L.Owen

Weight: 22,549

